

WEAR™ Pipe Restraint Vibration Isolator

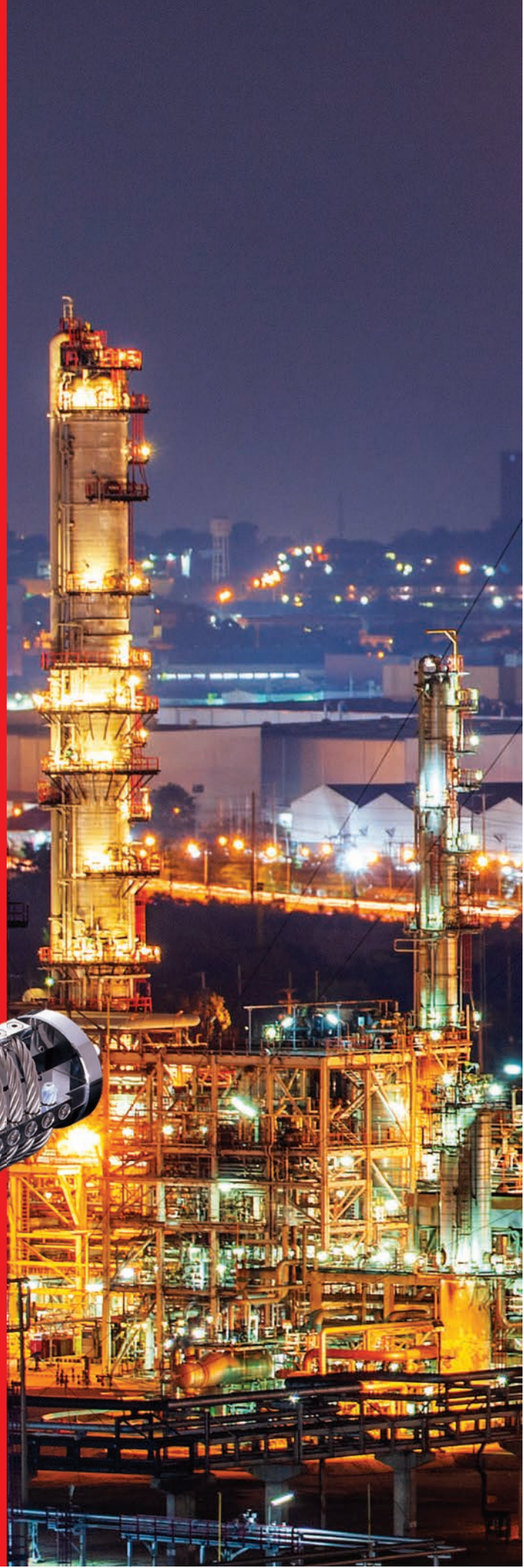

ENIDINE



Introducing WEAR™ Pipe Restraint and Vibration Isolator

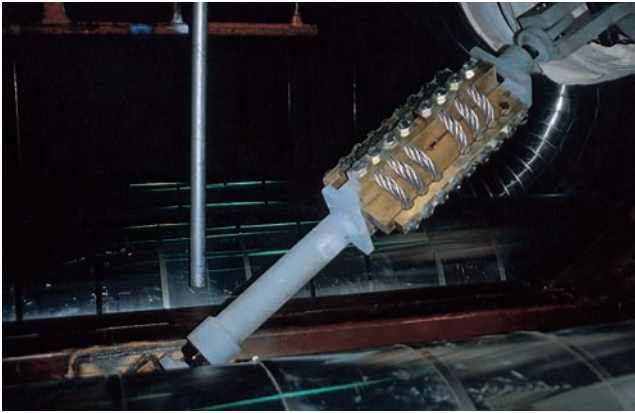

WEAR™ (Wire Energy Absorbing Rope) pipe restraints are uniquely packaged wire rope isolators designed to protect structures from steady state vibration and restrain them from seismic and dynamic loads. The WEAR™ pipe restraint will cushion, restrain and reduce energy into the structure through damping and will compensate for thermal expansion.

These new generation energy absorbing restraints feature simple construction. There are no oils, seals or complex moving parts required to perform their function. The design has eliminated the problems often associated with hydraulic or mechanical restraints which are complex and prone to failure.

The Wire Rope Isolator, which is the basic element of the technology, has been successfully used by the military for more than 25 years. As a result, it conforms to government, military and nuclear quality control requirements. The restraint is nuclear qualified and exempt from surveillance testing.

In-place visual inspection is all that is required to assure operability. The WEAR™ is provided with a wide range of piping accessories and can be supplied to ISO 9001, Mil-Q, Mil-I, B31.1 or ASME Section III subsection NF.

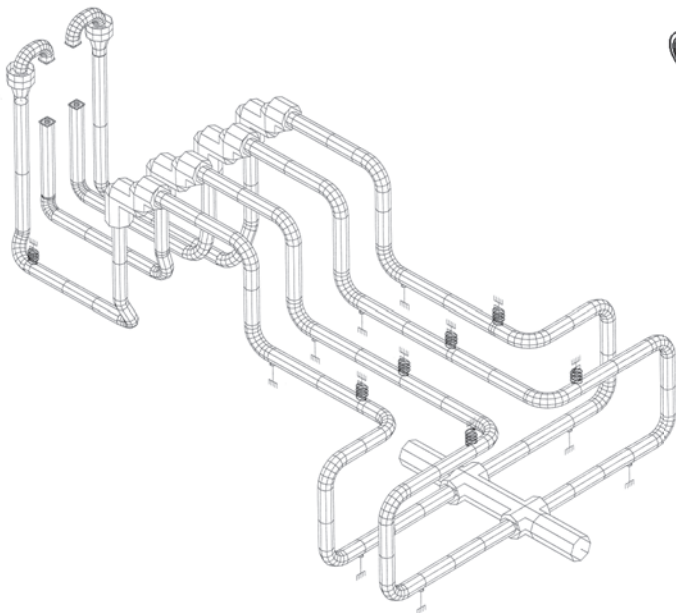

Options Available

Various end connections are available to meet existing hardware such as Lisega, Bergen Paterson, Basic Engineers, PSA, Grinnel, Anvil and others. For sizing or specific application information, call your local representative or Enidine directly.

Typical Applications

- Pipe Restraint
- Hydraulic Transients
- Power Generating Plants
- Chemical Plants
- Coker Units
- Seismic Restraints
- Steady State Vibration
- Nuclear Plants
- Refineries
- Structural Vibration
- Wind Loading
- Pulp and Paper Mills

WEAR™ Benefits

- Controls Flow Induced Steady-State Vibrations
- Seismic/Transient Event Protection
- Thermal Expansion Compensation
- No Fluids - No Maintenance
- Corrosion Resistant

Environmental Conditions

Normal Temperature:	-40° to 200° F
Faulted Temperature:	-40° to 350° F
Humidity:	100% RH
Radiation:	1 x 10 ⁹ RAD
Pressure:	7 psia to 70 psia

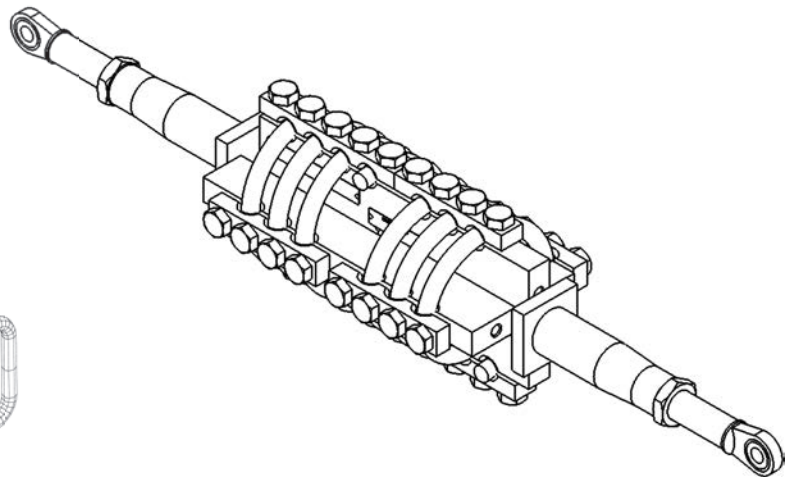

WEAR™ Pipe Restraint Dimensional Data

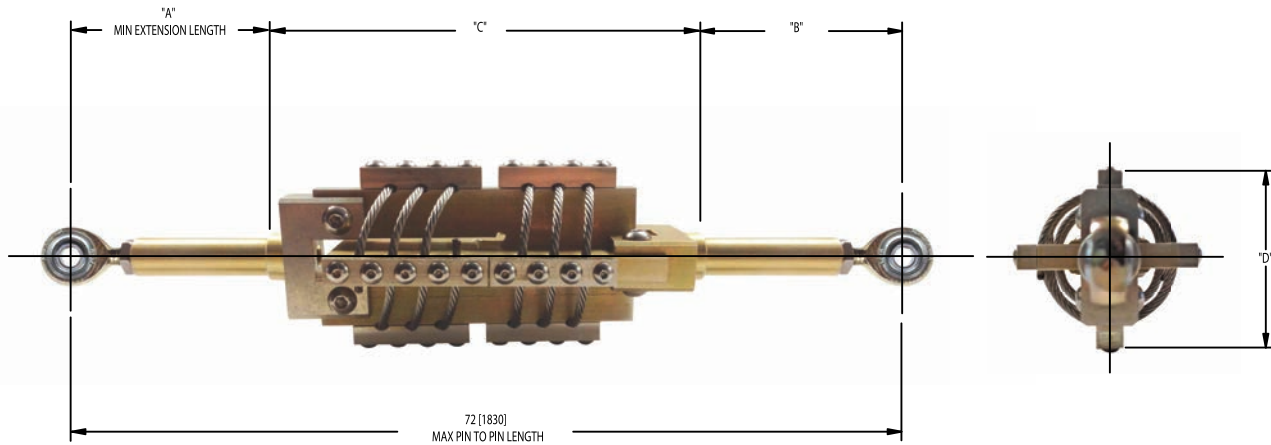

WEAR™ Restraint Model No.	Rated Load (Kips)	Stroke (in.)	Mid-Stroke Spring-Rate (Kips/in.)	Max-Stroke Spring-Rate (Kips/in.)	Min. Pin-Pin Length*	WEAR™ Dimensions				Total Min. Weight (lbs.)	Add. Weight per extension (lbs./in.)
						Length A (in.)	Length B (in.)	Length C (in.)	Diameter D (in.)		
WEAR 1.5 - 1.0 - 23	1.5	± 1.0	0.6	1.5	23	6.43 ± .75	6.43 ± .75	10.15	7.94	155	0.2
WEAR 1.5 - 0.5 - 22		± 0.5	1.2	3.0	22	6.43 ± .75	6.43 ± .75	9.15	4.77	155	0.2
WEAR 3.0 - 1.5 - 29	3.0	± 1.5	0.8	2.0	29	7.47 ± .75	7.47 ± .75	14.05	11.56	730	0.3
WEAR 3.0 - 1.0 - 27		± 1.0	1.2	3.0	27	7.26 ± .75	7.26 ± .75	12.47	8.26	485	0.3
WEAR 3.0 - 0.5 - 27	6.0	± 0.5	2.4	6.0	27	7.61 ± .75	7.61 ± .75	11.78	5.24	320	0.3
WEAR 6.0 - 2.0 - 34		± 2.0	1.2	3.0	34	7.45 ± .75	7.45 ± .75	19.09	15.72	1600	0.3
WEAR 6.0 - 1.5 - 33	6.0	± 1.5	1.6	4.0	33	7.45 ± .75	7.45 ± .75	18.09	12.21	1200	0.3
WEAR 6.0 - 1.0 - 29		± 1.0	2.4	6.0	29	7.69 ± .75	7.69 ± .75	13.62	8.60	670	0.3
WEAR 6.0 - 0.5 - 28	12.0	± 0.5	4.8	12.0	28	7.48 ± .75	7.48 ± .75	13.03	5.72	440	0.3
WEAR 12 - 2.0 - 40		± 2.0	2.4	6.0	40	9.29 ± .75	9.29 ± .75	21.41	16.55	2600	0.4
WEAR 12 - 1.5 - 38	12.0	± 1.5	3.2	8.0	38	9.37 ± .75	9.37 ± .75	19.25	13.05	1870	0.4
WEAR 12 - 1.0 - 37		± 1.0	4.8	12.0	37	9.23 ± .75	9.23 ± .75	18.53	9.91	1350	0.4
WEAR 24 - 2.0 - 50	24.0	± 2.0	4.8	12.0	50	12.0 ± .75	12.0 ± .75	26.00	18.36	4460	1
WEAR 24 - 1.5 - 47		± 1.5	6.4	16.0	47	12.14 ± .75	12.14 ± .75	22.72	14.75	3320	1

*Pin-to-pin is ± 1.5 inches.

** Additional lengths and customizations are available, please contact factory.

Load vs. Deflection Curve

The damping effect of the WEAR™ is illustrated in the plot as a hysteric loop which energy is dissipated by the WEAR™ restraint.

It is recommended that the total thermal travel of the WEAR™ device does not exceed 75% of the total travel capacity of the WEAR™ restraint.

At 100% of the maximum deflection the WEAR™, it becomes a rigid unit.

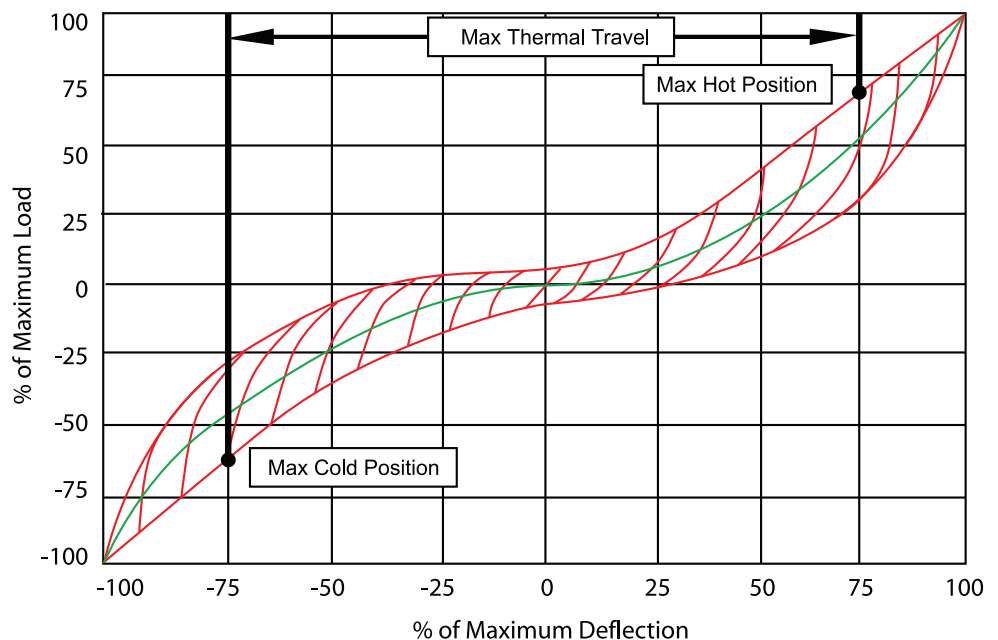

Enidine
7 Centre Drive
Orchard Park, New York 14127 • USA
Phone: 716-662-1900
Fax: 716-667-1909
Email: industrialsales@itt.com
www.enidine.com